

Model **138-ACC** Horizontal Power Conveyor
(Accumulating Type)

The simplest method ever devised for accumulating cartons, boxes, etc. Basic design eliminates complicated adjustments and allows a minimum of 2% back pressure.



- ★ 4 Bed Widths
- ★ 2% Minimum Back Pressure
- ★ Finger Tip Snub Roller Adjustment, No Tools Needed
- ★ Reversible
- ★ Adjustable LS-Type Floor Supports Available

ACCUMULATION - MINIMUM PRESSURE

SIZE TO ORDER Overall Length "A"	Between Rail Width	10"	13"	16"	22"
	Overall Frame Width	12"	15"	18"	24"
5'	WEIGHTS (Lbs.) Weights Based on 3" Roller Centers	183	192	200	226
10'		276	294	306	345
15'		369	399	412	467
20'		462	502	518	589
25'		555	605	624	711
30'		648	708	730	833
35'		741	811	836	955
40'		834	914	942	1077
45'		927	1017	1048	1199
50'		1020	1120	1154	1321
55'		1113	1223	1260	1443
60'		1206	1326	1366	1565
65'		1299	1429	1472	1687
70'		1392	1532	1578	1809
75'		1485	1635	1684	1931
80'		1578	1738	1790	2053
85'	1671	1841	1896	2175	
90'	1764	1944	2002	2297	
95'	1857	2047	2108	2419	
100'	1950	2150	2214	2541	

All weights in catalog are **conveyor weights only**.

Accessories, crating, etc., are not included.

NOTE: Stockyard drives are located on 10 ft. beds only.

NOTE: Intermediate bed sections are available in multiples of 4 ft., 5 ft., 6 ft., 7 1/2 ft., 8 ft., and 10 ft. lengths only.

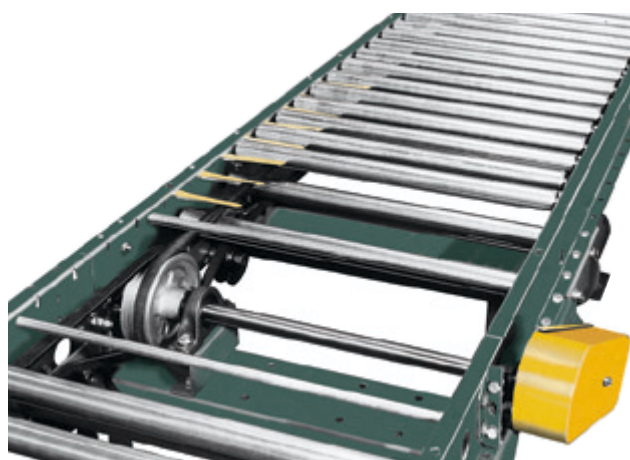

Conveyor sections are easily coupled together at either end to make up to 100 ft. long units. Drive is usually located near center of conveyor.

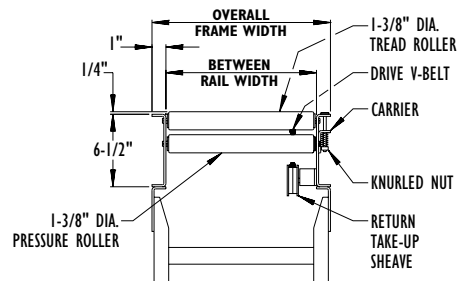
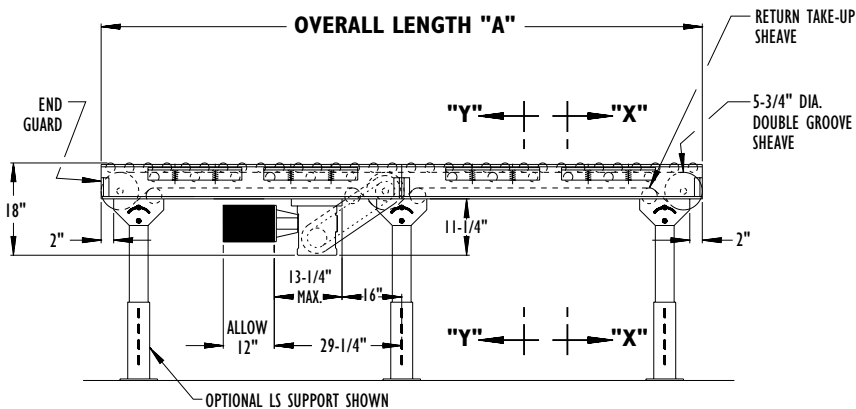

SECTION "X-X"

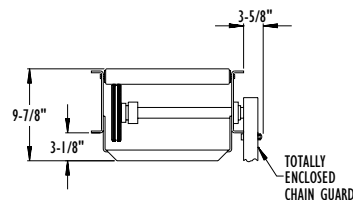

SECTION "Y-Y"

Standard Specifications

BED—Roller bed with 1-3/8 in. dia. roller x 18 ga. galvanized tube spaced every 3 in. and 1-3/8 in. dia. pressure roller x 18 ga. galvanized tube spaced every 6 in. Mounted in 6-1/2 in. x 12 ga. powder painted formed steel channel frame bolted together with butt couplings.

CROSS BRACING—Rods with turnbuckles are fastened to underside of bed to provide proper alignment of bed rollers and insure correct product tracking. Supplied on every other section 30 ft. lengths and over.

DRIVE—Mounted underneath, placed near center of conveyor.

DRIVE BELT—Endless B-section aramid core V-Belt drives each section of conveyor.

RETURN TAKE-UP SHEAVE—3-1/4 in. dia. x 1/2 in. bore flat idler has seven position adjustment to maintain proper V-belt tension.

BEARINGS—Sealed, pre-lubricated ball bearings with eccentric lock collar on flange and pillow block bearings. Pre-lubricated ball bearings in tread & pressure rollers.

SPEED REDUCTION—Sealed worm gear C-Face speed reducer. No. 50 roller chain to drive shaft.

MOTOR—1/2 HP—230/460V—3 Ph. 60 Hz. Totally Enclosed C-Face.

CONVEYING SPEED—Constant 65 FPM.

CAPACITY—Maximum load per linear foot of conveyor 50 lbs. NOT TO EXCEED capacity in chart.

FLOOR SUPPORTS—Now supplied as optional equipment.

How It Works!

The driving of the tread rollers on the HYTROL minimum pressure conveyor is accomplished with the top surface of a standard section endless V belt. The strength and wear qualities of the tread rollers and this belt have been thoroughly tested for continuous duty.

To maintain the driving of the tread roller, the pressure roller is mounted in spring adjusted carriers (See Photo) which sense the required driving friction regardless of the length of accumulated load. This pressure can be maintained constantly to give a 2% minimum back pressure in either a forward or reverse direction.

In the event of extreme changes in unit load (weight of box or package), convenient knurled thumb adjusting nuts can be turned to accept this heavier load.

This method eliminates the need for selecting proper tension spring holes in trigger mechanisms or jogging cleats on driving belt and eccentric (off center) tread rollers.

By maintaining a constant minimum pressure on the tread rollers, long loads may be conveyed, accumulated or stopped on the conveyor at any point using very little motor horsepower and giving practically no pressure between boxes or packages.

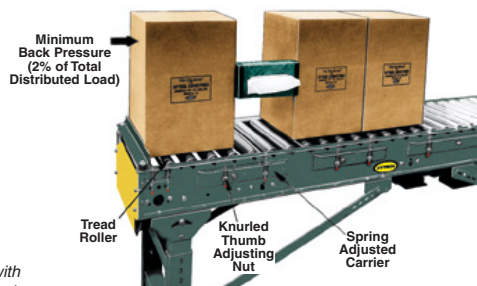

Conveyor shown with optional floor supports

LOAD CAPACITY CHART @ 65 FPM	
HP	OVERALL FRAME WIDTHS—12" TO 24"
	TOTAL LOAD (Lbs.)
	UP TO 100'
1/2	1000
3/4	1500

Optional Equipment

FLOOR SUPPORTS—LS Type floor supports are available with a wide range of adjustment. Specify top of belt or roller elevation. One support required at every bed joint and ends of conveyor. Holes in feet for lagging to floor. Knee braces recommended above LS-6 support.

CONVEYING SPEED—Other constant and variable speeds from 25 to 90 FPM. **NOTE: Capacity and accumulation feature affected with speed change.**

SIDE MOUNTED DRIVE—Motor reducer unit mounted to side of conveyor. Minimum elevation with standard sheave retainer 10 in. With low elevation sheave retainer 8 in. 9-3/8 in. elevation at drive, 9-7/8 in. elevation with standard sheave return. 8 in. elevation with low elevation sheave return (intermediate only).

V-BELT DRIVE—V-belt supplied between motor and reducer. Minimum overall drive width 14 in.

O-RING DRIVE CHAIN—With sealed in lubricant (Recommended for applications that do not permit regular lubrication).

PACKAGE STOPS—Blade, roller or pin type stops available, contact factory.

GUARD RAILS—Continuous adjustable channel, fixed channel or type A & B angle. See Accessory section. **NOTE: If product comes in contact with guard rails, product flow will be affected.** Fixed channel overlapping, one direction. Fixed channel nonoverlapping, reversing.

ROLLER CENTERS—Tread rollers spaced every 1-1/2 in.

HEX SHAFTS—5/16 in. hex shaft in place of 1/4 in. dia. round shaft.

SPRING BALANCED GATE—4 ft. or 5 ft. (maximum) long gate section chain driven from 138-ACC unit. Includes supports and gate rest. Clearance: 35-1/2 in. (4 ft. gate), 47-1/2 in. (5 ft. gate). Minimum elevation 15 in.

POLY-TIER SUPPORTS—36 in. to 120 in. support heights in 6 in. increments. Knee braces supplied.

CEILING HANGERS—5/8 in. dia. x 8 ft. long unplated rods fully threaded. Other lengths and galvanized rods available.

MOTORS—Energy efficient, single phase, other characteristics. 3/4 HP maximum.

ELECTRICAL CONTROLS—Non-reversing or reversible magnetic starters and push-button stations. AC variable frequency drive.