

# Model 190-NSP Live Roller Conveyor

The Model 190-NSP Live Roller Spool Conveyor is a general transport conveyor with the capabilities of accumulating products with back pressure.

Quiet operation, versatile design, easy installation and maintenance make the 190-NSP conveyor a valuable component in operations requiring high performance with minimal downtime.



Conveyor shown with optional floor supports



- ★ 12 Bed Widths
- ★ Reversible
- ★ Adjustable MS-Type Floor Supports Available

L I V E R O L L E R

SIZE TO ORDER Overall Length "A"	Between Rail Width	13"	15"	17"	19"	21"	23"	25"	27"	31"	33"	37"	39"
	Overall Frame Width	16"	18"	20"	22"	24"	26"	28"	30"	34"	36"	40"	42"
5'	WEIGHTS (Lbs.) Based on 3" Roller Centers	229	236	249	259	272	284	293	307	329	341	364	376
10'		371	384	409	426	450	472	488	514	553	576	618	639
15'		513	533	569	594	629	660	684	721	778	811	872	902
20'		655	682	729	761	808	848	880	928	1003	1046	1126	1166
25'		797	830	889	929	987	1036	1076	1135	1228	1281	1380	1429
30'		939	979	1049	1096	1166	1224	1271	1342	1453	1517	1634	1692
35'		1082	1128	1209	1264	1344	1413	1467	1549	1678	1752	1888	1956
40'		1224	1276	1369	1431	1523	1601	1663	1756	1903	1987	2142	2219
45'		1366	1425	1529	1599	1702	1789	1859	1963	2127	2222	2396	2483
50'		1508	1574	1689	1766	1881	1977	2054	2170	2352	2458	2650	2746
55'		1650	1723	1849	1934	2060	2165	2250	2377	2577	2693	2904	3009
60'		1793	1871	2009	2102	2238	2354	2446	2584	2802	2928	3158	3273
65'		1935	2020	2169	2269	2417	2542	2642	2791	3027	3163	3412	3536
70'		2077	2169	2329	2437	2596	2730	2837	2998	3252	3399	3666	3800
75'		2219	2317	2489	2604	2775	2918	3033	3205	3477	3634	3920	4063
80'		2361	2466	2649	2772	2954	3106	3229	3412	3702	3869	4174	4326
85'	2503	2615	2809	2939	3133	3294	3425	3619	3926	4104	4428	4590	
90'	2646	2764	2969	3107	3311	3483	3620	3826	4151	4340	4682	4853	
95'	2788	2912	3129	3274	3490	3671	3816	4033	4376	4575	4936	5117	
100'	2930	3061	3289	3442	3669	3859	4012	4240	4601	4810	5190	5380	

All weights in catalog are conveyor weights only. Accessories, crating, etc., are not included.

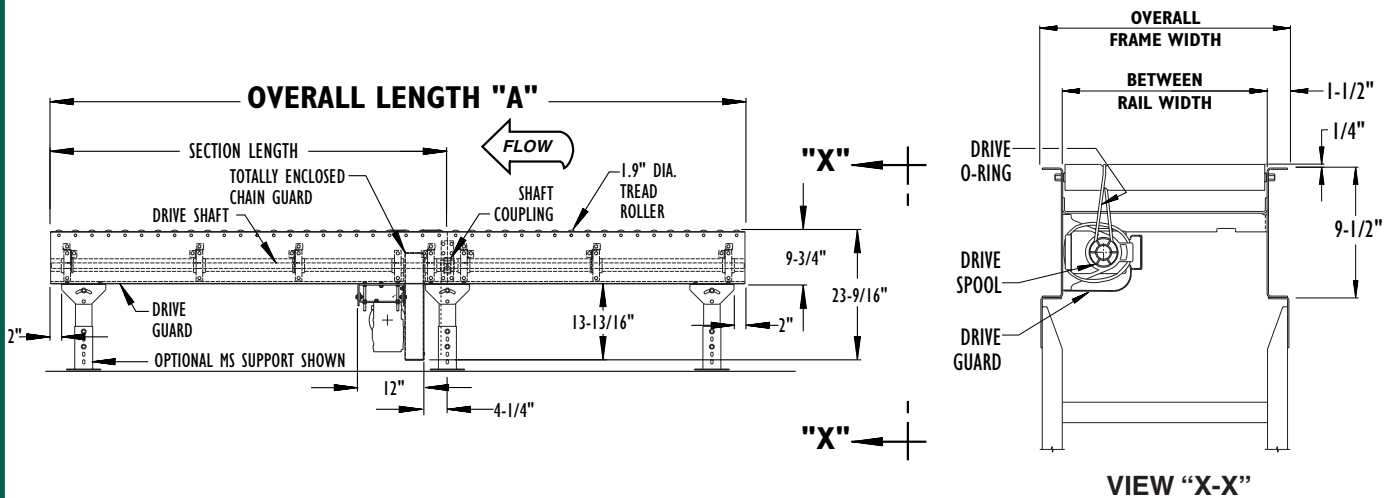

## Standard Specifications

**BED**—Roller bed with 1.9 in. dia. roller x 16 ga. galvanized tube spaced every 3 in. Mounted in 9-1/2 in. x 12 ga. powder painted formed steel channel frame bolted together with splice plates.

**CROSS BRACING**—Rods with turnbuckles are fastened to underside of bed to provide proper alignment of bed rollers and insure correct product tracking. Supplied on every other section 30 ft. bed lengths and over.

**DRIVE**—Mounted underneath, placed near center of conveyor. **NOTE: On Conveyors less than 24 in. OAW motor extends beyond frame.** Chain guard located on left hand side.

**DRIVE SHAFT**—1 in. dia. steel shaft extends full length of conveyor. Chain coupling at bed joints. Located on left hand side.

**DRIVE SPOOLS**—2 in. dia. Delrin spool held in place on drive shaft with spool spacers.

**DRIVE GUARD**—Underside of drive shaft with spools and drive o-rings guarded full length of conveyor.

**DRIVE O-RING**—3/16 in. dia. polyurethane o-ring from drive spool to tread rollers.

**BEARINGS**—Sealed, pre-lubricated, self-aligning, ball bearings with eccentric lock collar on drive shaft. Pre-lubricated ball bearings in tread rollers.

**SPEED REDUCTION**—Sealed worm gear C-Face speed reducer. No. 50 roller chain to drive shaft.

**MOTOR**—1/2 HP—230/460V—3 Ph. 60 Hz Totally Enclosed C-Face.

**CONVEYING SPEED**—Constant 65 FPM.

**CAPACITY**—Maximum load per powered roller—15 lbs. **NOTE: Maximum load capacity will be less for products with soft or irregular bottoms.** Total load NOT TO EXCEED capacity in chart.

**FLOOR SUPPORTS**—Now supplied as optional equipment.

### How It Works!

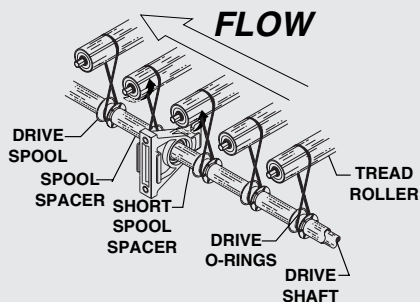

- 1) Powered **drive shaft** (coupled at bed joints) is bearing supported on frame.
- 2) **Drive o-ring** transmits power to **tread rollers** from **drive shaft**.
- 3) **Drive spool** (held in place by **spool spacers**) and groove in **tread roller** keep drive o-ring in position.
- 4) If back pressure (accumulation) is applied to **tread roller**, **drive spool** will slip on **drive shaft**, stopping power to **tread roller**.

LOAD CAPACITY CHART @ 65 FPM

HP	OVERALL FRAME WIDTH 16" to 22"			OVERALL FRAME WIDTH 24" to 30"			OVERALL FRAME WIDTH 34" to 42"		
	TOTAL LOAD (Lbs.)			TOTAL LOAD (Lbs.)			TOTAL LOAD (Lbs.)		
	UP TO 60'	UP TO 90'	UP TO 120'	UP TO 60'	UP TO 90'	UP TO 120'	UP TO 60'	UP TO 90'	UP TO 120'
1/2	1550	580	—	1340	250	—	1020	—	—
3/4	3310	2330	1360	3090	2010	920	2770	1530	280
1	*3600	4090	3110	*3600	3770	2680	*3600	3280	2040
1 1/2	—	*5400	6620	—	*5400	6190	—	*5400	5550
2	—	—	*7200	—	—	*7200	—	—	*7200

\*Limited to 15 lbs. per driven roller. NOTE: Capacity in Chart based on 3 in. roller centers with all rollers powered.

MOTOR SELECTION CHART

FPM	30-44	45-59	60-120
HP (MAX)	1	1-1/2	2

If the required horsepower exceeds the maximum horsepower shown in the chart, more than one drive is required

## Optional Equipment

**FLOOR SUPPORTS**—MS Type floor supports are available with a wide range of adjustment. Specify top of belt or roller elevation. One support required at every bed joint and ends of conveyor. Holes in feet for lagging to floor. Knee braces recommended above MS-6 support.

**CONVEYING SPEED**—Other constant and variable speeds from 30 to 120 FPM. Over 120 FPM timing belt drive recommended. **Capacity affected with speed change.**

**O-RING DRIVE CHAIN**—With sealed in lubricant (Recommended for applications that do not permit regular lubrication).

**LOW ELEVATION DRIVE**—Gearmotor mounted inside of conveyor. Minimum elevation 11-3/4 in.

**POSITIVE DRIVE**—Spools are keyed to drive shaft in positive drive areas.

**CROSSOVER**—Separate section relocates drive shaft from one side of conveyor to the other. Minimum Elevation—12-3/8 in.

**ONE DIRECTION O-RING TRANSFER**— See Conveyor Accessories.

**REVERSING O-RING TRANSFER**— See Accessories section.

**GUARD RAILS**—Continuous adjustable channel, fixed channel or type A & B angle. **NOTE: If product comes in contact with guard rails, product flow will be affected.** Fixed channel overlapping, one direction. Fixed channel non-overlapping, reversing.

**PACKAGE STOPS**—Blade, roller or pin type stops available, contact factory.

**POLY-TIER SUPPORTS**—36 in. to 120 in. support heights in 6 in. increments. Knee braces supplied.

**CEILING HANGERS**—5/8 in. dia. x 8 ft. long unplated rods fully threaded. Other lengths and galvanized rods available.

**MOTORS**—Energy efficient, single phase, other characteristics. 2 HP maximum.

**ELECTRICAL CONTROLS**—Non-reversing or reversible magnetic starters and push-button stations. AC variable frequency drive.