

ED

Electric Chain Hoists



MODEL: ED525DA



MODEL: ED250S



Ergonomically designed for maximum load control

Harrington's ED single-phase electric chain hoist is engineered to handle small or awkward loads by providing precise load positioning and easy-to-use controls.

Expect big benefits from the one-of-a-kind cylinder control designed into the DA model. By using the in-line handgrip, which is part of the complete hook block, the up/down control becomes a one-handed operation. The operator's free hand is available to guide and position the load with reduced effort and increased accuracy.

Increase your productivity

Applications

- Work stations and work cells
- Assembly lines
- Pick-and-place operations

Flexibility

- Cylinder or pendant control
- Custom speed control
 - High and low speeds adjustable from 0 to 100% of maximum speed in DA Model
- High speeds in all models support fast production applications
- Quick-change tool chuck for below-the-hook specialty devices

Compact Design

- Lightweight, die-cast aluminum body
- Low headroom
- Easily installed, transported or stored

Dependability

- Weston-style and regenerative load brakes
- Friction clutch for overwinding protection
- Zinc-plated, heat-treated load chain
- Standard upper limit switch

Ask your local sales representative or call our Customer Service staff for friendly and expert advice on models and options.

ED ELECTRIC CHAIN HOISTS—SPECIFICATIONS

Cap. (lbs)	Product Code			Lifting Speed (ft/min)		Standard Lift (ft)		Push Button Cord L (ft)		Motor Output (HP)	Intermittent Duty Rating		Short Time Duty Rating (min)	Rated Current at 120V (amps)
	Single Speed S Model	Dual Speed DS Model	Dual Adjustable DA Model	S Model	DS & DA Model	S & DS Model	DA Model	S & DS Model	DA Model		Duty Rating % ED	Max. Start Freq. (Times/Hr)		
125	ED125S	ED125DS	ED125DA	69	69/13	10	6	8	Coiled	0.4	30	180	15	5
220	ED220S	ED220DS	ED220DA	43	43/10						20	120	10	6
250	ED250S	ED250DS	ED250DA	26	26/10						30	180	20	10
350	ED350S	ED350DS	ED350DA	66	66/13						20	120	10	6
400	ED400S	ED400DS	ED400DA	26	26/10						30	180	20	10
525	ED525S	ED525DS	ED525DA	44	44/10						20	120	10	6

DIMENSIONS AND WEIGHTS

Cap. (lbs)	Headroom C (in)		a (in)	d (in)	e (in)	f (in)	g (in)	h (in)	i (in)	j (in)	k (in)	Net Weight (lbs)			Weight for Additional One Foot of Lift (lbs)	
	S & DS Model	DA Model										S Model	DS Model	DA Model	S Model	DS Model
125	12.4	37.2	14.6	7.4	7.2	8.1	1.0	4.9	3.1	1.0	13.4	23	24	31	0.26	0.29
220												24	25	32		
250												33	34	40		
350	13.0	37.8	16.9	8.1	8.8	8.6		5.3	3.3	14.3	24	25	32			
400	12.4	37.2	14.6	7.4	7.2	8.1		4.9	3.1	13.4	24	25	32			
525	13.0	37.8	16.9	8.1	8.8	8.6		5.3	3.3	14.3	33	34	40			

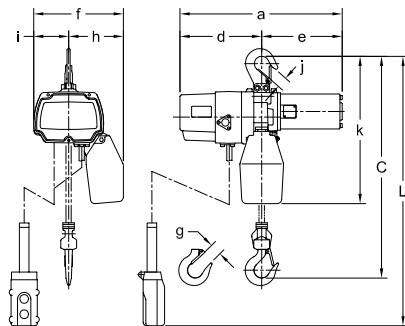

S and DS Models

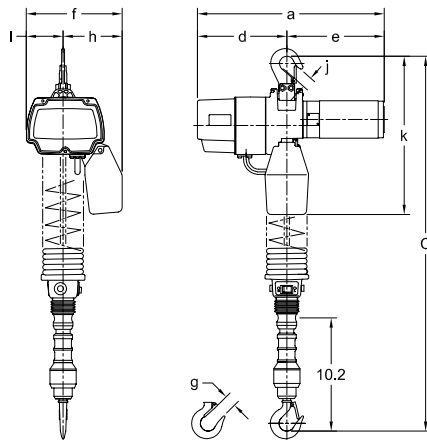

DA Model

*Speed are adjustable from 0 to 100% of maximum speed:
 DS—low speed only
 DA—low and high speeds

Dimensions for ED Dual Adjustable Model (inches)

ET525 MINI TROLLEY—SPECIFICATIONS AND DIMENSIONS

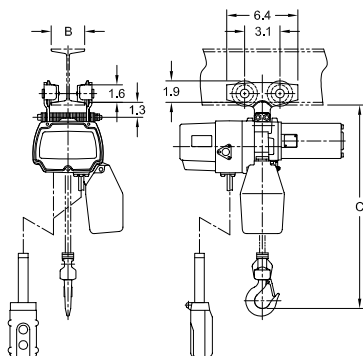

Maximum Capacity (lbs)	Product Code	Adjustable Beam Width B (in)	Minimum Radius for Curve (in)	Net Weight (lbs)	Approximate Shipping Weight (lbs)
525	ET525	1.97–3.94	23.6	4.0	5.0

Cap. (lbs)	Headroom C (in)	
	S & DS Model	DA Model
125	10.5	35.3
220		
250		
350	11.1	35.9
400	10.5	35.3
525	11.1	35.9



Harrington Hoists, Inc.
 401 West End Avenue, Manheim, PA 17545
 717-665-2000 / 800-233-3010 / Fax: 717-665-2861
 www.harringtonhoists.com

Harrington Hoists, Inc.—Western Division
 2341 Pomona Rincon Road, No. 103
 Corona, CA 92880-6973
 951-279-7100 / 800-317-7111 / Fax: 951-279-7500

Specifications and dimensions are subject to change without notice.
 Rev 3 Copyright © 2001 1-05
 Item No. SS-ED